

RAPID PROTOTYPING TECHNOLOGIES A BOON TO MANKIND



Mr. Kiran. R*

**Professor & Dean, AIBM College, Bangalore-560056, Karnataka, India*

ABSTRACT

In the era of globalisation, there is competition for producing best quality of products at lower costs in lesser lead-time. Product complexity is increasing while product cycles are growing ever shorter. The lead-time for producing products varies from few weeks to few months by conventional and CAD/CAM/CNC technologies. Rapid Prototyping (RP) technologies can be considered when the reduction of time to market is important, for prototype parts and for tooling with short to medium volume production runs. Rapid Prototyping refers to producing prototype parts and tooling by layer-by-layer manufacturing techniques. Rapid Prototyping technologies can reduce the lead-time and cost in product development stage. Different Rapid Prototyping technologies are commercially available in the market. Stereo lithography apparatus (SLA), Fused Deposition Modelling (FDM), Laminated Object Manufacturing (LOM), Direct Metal Laser Sintering (DMLS) technology, Selective Laser Sintering (SLS), Laser Engineered Net Shaping (LENS) are some of the commercially available RP technologies. This paper deals with the rapid prototyping principle, different types of RP technologies, RP applications and future developments in RP.

KEY WORDS: Prototype, CAD/CAM, Sintering

1.0 INTRODUCTION

In the era of globalisation, there is competition for producing best quality of products at lower costs in lesser lead-time. Prototype parts can be produced using tooling or directly by machining. Quality products can be produced only with quality tools. Tooling encompasses a wider area of manufacturing. Tooling is required in aerospace, automobile, electrical, electronics & white goods industry etc., Forging dies, die casting dies, plastic moulds, sheet metal forming dies and jig & fixture form a major portion of tooling. CAD/CAM & CNC machining, EDM and wire cut EDM technologies are widely used for producing tooling. The lead-time for producing a tool varies from few weeks to few months.

Even for a very low batch production, the lead-time cannot be cut down drastically with the existing CAD/CAM/CNC technologies. In order to bring out a product to the market in lesser lead-time, advanced manufacturing technologies like Rapid Prototyping (RP) technologies are currently available. The term Rapid Prototyping (RP) refers to a class of technologies that can automatically construct physical models directly from Computer Aided Design (CAD) data.

Different rapid prototyping technologies are commercially available in the market, each with unique capability. Stereo- lithography (SLA), Fused deposition modeling (FDM), Laminated object manufacturing (LOM), Selective Laser Sintering (SLS) & Direct metal laser sintering (DMLS) are some of the most commonly used RP technologies. Using these technologies, the lead-time for producing tooling can be drastically reduced. to the market in lesser lead-time, advanced manufacturing technologies like Rapid

Prototyping (RP) technologies are currently available.

RP allows designers to quickly create tangible prototypes of their designs rather than just 2-dimensional pictures. Unlike conventional machining processes that are subtractive in nature, RP systems join together liquid, powder and sheet materials to build 3D parts. It is a Layer-by-layer building technology. RP machines fabricate Plastic, Ceramic and Metal objects using horizontal cross sections from a computer-generated model, thereby reducing product development time drastically.

In addition to prototypes, RP techniques can also be used to make Tooling referred to as Rapid Tooling-RT for small production runs and complicated objects.

2. RAPID PROTOTYPING

The term Rapid Prototyping (RP) refers to a class of technologies that can automatically

construct physical models directly from Computer Aided Design (CAD) data. It is a layer-by-layer manufacturing technology.

2.1 RP process steps:-

Although several Rapid Prototyping Techniques exists, all employ the same basic five-step process. The steps are

1. Creation of 3D CAD model of Part.
2. Converting the CAD model to STL (Stereo lithography) format.
3. Converting the STL file into thin cross-section layers using CAD system.
4. Building physical model one layer atop another.

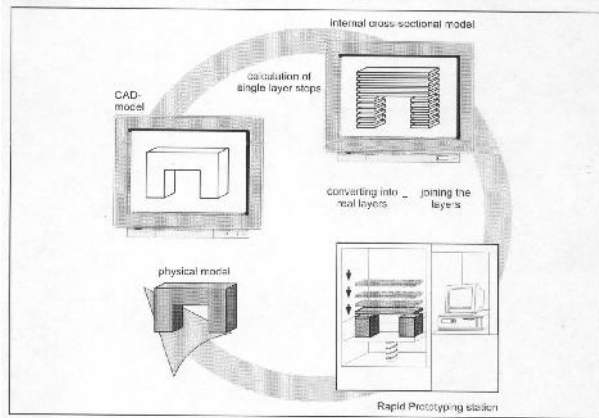

Fig1: RP Process Steps

First, the object to be built is modelled using a Computer Aided Design (CAD) Software Package, Solid models tend to represent 3-D object more accurately than wire frame Models and will therefore yield better results. The designer can use a pre-existing CAD file or may wish to create one expressly for prototyping purposes.

The second step, is to convert the CAD file into STL format. This format represents a three-dimensional surface as an assembly of planar triangles. The file contains the co-ordinates of the vertices and the direction of the outward normal to each triangle because STL use planar elements. They cannot represent curved surfaces exactly. Increasing the number of triangles improves the approximation, but the cost of bigger file size, large complicated files require more time to pre-process and build, so the designer must balance accuracy with manageability to produce a useful STL file. The various CAD packages use a number of different algorithms to represent solid objects. To establish consistency, the STL (Stereolithography, the first RP technique) format has been adopted as the standard of the Rapid Prototyping industry.

In the third step, the pre-processing software slices the STL model into a number of layers from 0.01mm to 0.7 mm thick, depending on the RP technique. The program may also develop an auxiliary

structure to support the model during the build. Supports are useful for delicate features such as overhangs, internal cavities, and thin walled sections.

The fourth step is actual construction of the part. Parts can be built using paper, metal, wax or plastic material depending on the type of RP technology. Paper is used in the form of sheets and plastic & metal is used in the form of powder.

2.2 Different types of RP Technologies:-

Some of the technologies currently available for physically producing the Rapid Prototype models are:

- ◆ Laminated object manufacturing (LOM)
- ◆ Stereo lithography Apparatus (SLA)
- ◆ Fused Deposition Modeling (FDM)
- ◆ Selective laser sintering (SLS)
- ◆ Direct Metal Laser Sintering (DMLS)

2.2.1 Laminated Object Manufacturing (LOM):

Paper in the form of a roll is used as raw material for Part building. Laser (as per cross section of part) cuts the paper and the cut papers are stacked automatically & thus the part is built.

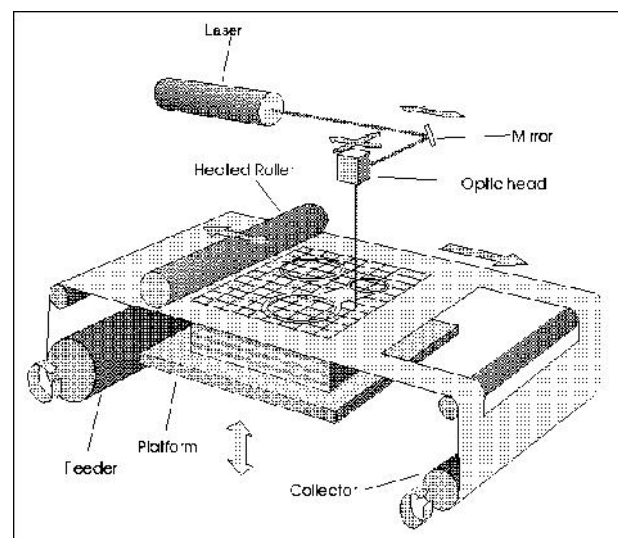

Fig.2 Laminated Object Manufacturing (LOM)

Applications of LOM RP Parts:

The RP parts are used in the applications such as:

- Investment Casting;
- Silicon Rubber moulding.
- Spray metal moulds.
- Vacuum forming for plastics.
- Sand casting.

2.2.2 Stereo Lithography (SLA):-

This process relies on a photosensitive liquid resin which forms a solid polymer when exposed to ultraviolet(UV) light. Due to the absorption and scattering of the beam, this reaction only takes place near the surface.

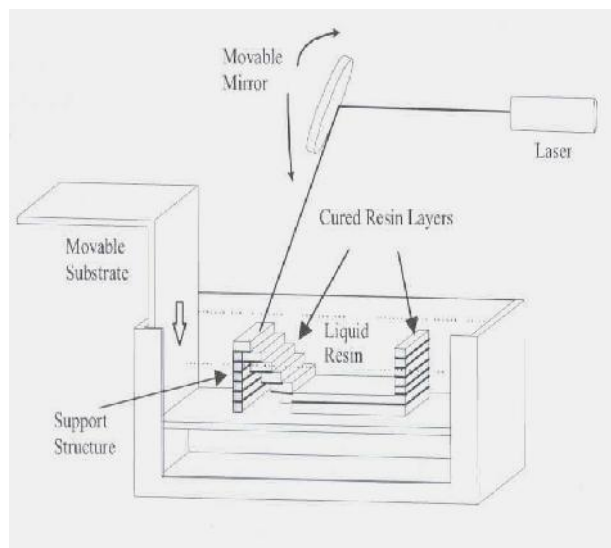

Fig.3 Stereo-Lithography Apparatus (SLA)

Applications of SLA RP Parts:

The RP parts are used in the following applications:

- As a prototype for concept design, form/fit/function testing.
- Silicon Rubber moulding.
- Patterns for sand casting and investment casting.
- AS the RP Parts are transparent, they are used in stress analysis applications.

2.2.3 Fused Deposition Modeling (FDM):-

FDM process is a filament-based system, which feeds the material into the extrusion head and heats it to a semi-liquid state. ABS is the most commonly used material in the form of a filament. The molten material is deposited layer-by-layer to get the final product. No laser is used in this process.

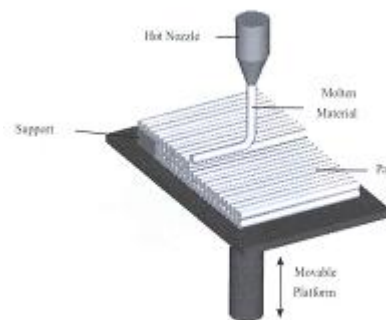

Fig.4 Fused Deposition Modelling (FDM)

Applications of FDM RP Parts:-

The RP parts are used in the following applications:

- As a prototype for concept design, form/fit/function testing.
- Silicon Rubber moulding.
- Patterns for sand casting and investment casting.

2.2.4 Selective laser sintering (SLS):-

The Selective Laser Sintering process creates three-dimensional objects, layer-by-layer, from powdered materials with heat generated by a CO₂ laser within the sinter station. Materials such as Nylon, polystyrene, Polycarbonate, & metal /sand powders (coated with suitable binders) are used as raw material for building the part.

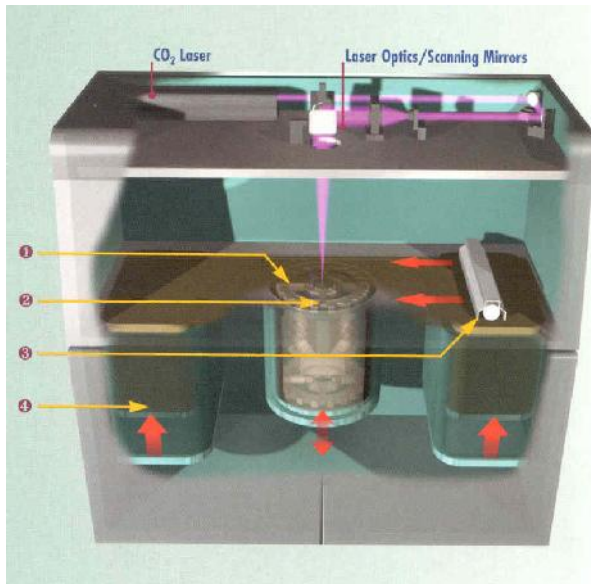

Fig.5 Selective Laser Sintering

Applications of SLS RP Parts:

The RP parts are used in the following applications:

- As a prototype for concept design, form/fit/function testing.
- Patterns/Core/Cavity for tooling applications.

2.2.5 Direct Metal Laser Sintering (DMLS):-

This process is similar to SLS process. Using this technology, metal, sand & plastics can be sintered by laser. The toolings produced by this process can be directly used as core/ cavity/pattern, unlike in SLS process where it has to be post treated (in-filtered) with other material.

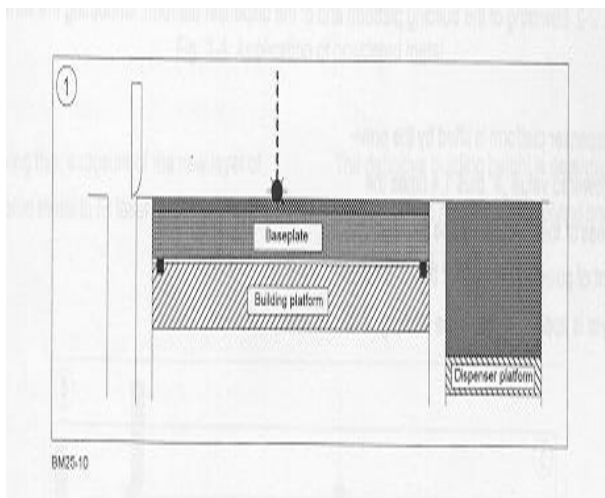

Fig.6 Direct Metal Laser Sintering (DMLS)

Applications of DMLS RP Parts:

The RP parts are used in the following applications:

- As a prototype for concept design, form/fit/function testing.
- Patterns/Core/Cavity for tooling applications.

3.0 ADVANTAGES OF RAPID PROTOTYPING TECHNOLOGIES

Apart from the enormous time and cost savings, rapid prototyping has several advantages:

- ✱ A physical model that can be produced quickly straight from CAD files, can allow form, fit and function tests much earlier in the design cycle.
- ✱ Errors from incorrect interpretation of the design are reduced and designs to Prototype iterations are faster.
- ✱ It is possible to go from a CAD model to a prototype without using a skilled machinist, a fixture designer or a NC programmer.
- ✱ Core/Cavity can be built for plastic moulding, investment casting, and die-casting applications.
- ✱ Apart from directly producing plastic prototype models, some of the parts produced can be used as patterns for investment or sand casting, depending on the technology used.
- ✱ Longer lead-time is required for producing dies and moulds by conventional machining process. Using rapid prototyping technologies, tooling can be produced in a shorter time. This helps in bringing the products to the market in a lesser time.

4. FUTURE DEVELOPMENTS IN RAPID PROTOTYPING

- * Faster computers, complex control systems and improved materials will be the future of RP systems to reduce build time.
- * Improvements in part accuracy and surface finish can be achieved by improved laser optics and motor controls.
- * Introduction of non-polymeric materials including metals, ceramics and composites represents much anticipated developments in RP. In addition, metals and composite materials will greatly expand the range of products that can be made RP.
- * Currently most RP machines are limited to objects 0.125 cubic meters or less. Researchers at Penn states of Applied Research Laboratory (ARL) are aiming to directly build large metal parts using robotically guided lasers.
- * One future application is the distance manufacturing on demand, a combination of RP and internet will allow designers to remotely submit designs for immediate manufacture.

5. CONCLUSION

- ⊙ Rapid prototyping is an additive process to build prototype parts/ tooling by layer-by-layer building process.

- ⊙ Stereo lithography apparatus (SLA), Fused Deposition Modelling (FDM), Laminated Object Manufacturing (LOM), Direct Metal Laser Sintering (DMLS) technology, Selective Laser Sintering (SLS), Laser Engineered Net Shaping (LENS) are some of the commercially available RP technologies.
- ⊙ Parts/tooling can be directly produced from 3D CAD data.
- ⊙ Lead-time for manufacturing is reduced drastically from weeks to hours by using RP technology.
- ⊙ Using SLS and DMLS RP technology, metal prototype parts and tooling can be directly produced from 3D CAD data.
- ⊙ Prototype parts can be produced using metal powder, polyimides, paper & plastic sheet.
- ⊙ RP finds its application in aerospace, electrical, electronics, medical & automobile industries etc.,

REFERENCES

1. Prof.C.Gajendran, Prof. P.Radhakrishnan "Direct rapid tooling for complex geometrical components using Direct Metal Laser Sintering Process". 34th CIRP international seminar on manufacturing systems, May 2001.
2. Prof. C.Gajendran, C.K.Srinivas, R.S.Nadig, T.Gurumurthy, CMTI, Bangalore."Design of Prototypes & injection mould tooling for manufacturing by Direct Metal Laser Sintering technology". 2nd National Symposium on Rapid prototyping & rapid tooling, November 2001, Bangalore, organized by Rapid Prototyping Society of India.